

SECTION 10400

IDENTIFYING DEVICES

PART 1 – GENERAL

1.1 SUMMARY

- A. Requirement of Products Covered Under This Section: Provide and install interior and exterior room identification signs, geometric restroom signs, tactile exit signs and interior and exterior directional and informational signs including signs for accessible features, regulatory and life safety signs.
- B. Related Standards:
1. California Building Code (CBC Title 24, 2001) Sections 1114b, 1115B.5 and 117B.5.
 2. CBC Title 24 Fire Safety Code (Title 19, latest edition.)
 3. ADA Accessibility Guidelines (ADAAG, 1992 & 2010 edition, www.access-board.gov/ada-aba/final.htm)
 4. ICC/ANSI A117.1-1998. American National Standards. Accessible and Usable Buildings and Facilities. International Code Council. 5203 Leesburg Pike, Suite 703, Falls Church, VA 2204. (703-931-4533)
 5. Division of the State Architect, California, Checklist 17 (www.dsa.ca.gov)

1.2 SYSTEM DESCRIPTION FOR ADA ACCESSIBILITY GUIDELINES

703.1. General. Signs shall comply with 1.2. Where both visual and tactile characters are required, either on signs with both visual and tactile characters, or two separate signs, one with visual, and one with tactile characters, shall be provided.

703.2 Raised Characters. Raised characters shall comply with 703.2 and shall be duplicated in braille complying with 703.3. Raised characters shall be installed in accordance with 703.4

Advisory 703.2 Raised Characters. Signs that are designed to be read by touch should not have sharp or abrasive edges.
--

703.2.1 Depth. Raised characters shall be 1/32 inch (0.8 mm) minimum above their background.

703.2.2 Case. Characters shall be uppercase.

703.2.3 Style. Characters shall be sans serif. Characters shall not be italic, oblique, script, highly decorative, or of other unusual forms.

703.2.4 Character Proportions. Characters shall be selected from fonts where the width of the uppercase letter “O” is 55 percent minimum and 110 percent maximum of the height of the uppercase letter “I”.

703.2.5 Character Height. Character height measured vertically from the baseline of the character shall be 5/8” (mm) minimum and 2 inches (51 mm) maximum based on the height of the uppercase letter “I”.

EXCEPTION: Where separate raised and visual characters with the same information are provided, raised character height shall be permitted to be 1/2 inch (13 mm) minimum.

703.2.6 Stroke Thickness. Stroke thickness of the uppercase letter “I” shall be 15 percent maximum of the height of the character.

703.2.7 Character Spacing. Character spacing shall be measured between the two closest points of adjacent raised characters within a message, excluding word spaces. Where characters have rectangular cross sections, spacing between individual raised characters shall be 1/8 inch (3.2 mm) minimum and 4 times the raised character stroke width maximum. Where characters have other cross sections, spacing between individual raised characters shall be 1/16 inch (1.6 mm) minimum and 4 times the raised character stroke width maximum at the base of the cross sections, and 1/8” inch (3.2 mm) minimum and 4 times the raised character stroke width maximum at the top of the cross sections. Characters shall be separated from raised borders and decorative elements 3/8 inch (9.5 mm) minimum

703.2.8 Line Spacing. Spacing between the baselines of separate lines of raised characters within a message shall be 135 percent minimum and 170 percent maximum of the raised character height.

703.3 Braille. Braille shall be contracted (Grade 2) and shall comply with 703.3 and 703.4.

703.3.1 Dimension and Capitalization. Braille dots shall have a domed or rounded shape and shall comply with Table 703.3.1. The indication of an uppercase letter or letters shall only be used before the first word of sentences, proper nouns and names, individual letters of the alphabet, initials and acronyms.

703.3.1 Braille Dimensions

Measurement Range	Minimum in Inches Maximum in Inches
Dot base diameter	0.059 (1.5 mm) to 0.063 (1.6 mm)
Distance between two dots in the same cell ₁	0.090 (2.3 mm) to 0.100 (2.5 mm)
Distance between corresponding dots in adjacent cells ₁	0.241 (6.1 mm) to 0.300 (0.300 mm)
Dot height	0.025 (0.6 mm) to 0.037 (0.9 mm)
Distance between corresponding dots from one cell directly below ₁	0.395 (10 mm) to 0.400 (10.2 mm)

1.3 SUBMITTALS

- A. General: Submit in accordance with Section 01330.
- B. Product Data: Submit product data for each sign type of sign.
- C. Shop Drawings: Include drawing of each sign type, indicating size of sign plaque, sizes, type styles of characters, symbols and pictograms. Braille placement where applicable, materials, material thickness where applicable and colors of substrate and characters. Show installation detail.
- D. Samples: Provide one sample room identification sign demonstrating fabrication technique for tactile characters and Braille that follows California specifications.

1.4 QUALITY ASSURANCE

- A. Sign fabricators shall submit 3 references showing projects completed within the last 3 years. Both tactile and non-tactile signage shall be included in the work.
- B. A one year warranty shall be provided for all other signs or components of tactile signs, except for damage by mishandling by building owner, including installation by building owner or representative, or vandalism.

PART 2 – PRODUCT

2.1 MANUFACTURERS

- A. Provide products from Braille Signs, Inc. 16782 Von Karman Ave. Unit 30 Irvine CA, 92606. Phone (949) 797-1570, fax (949) 797-1573, website www.braillesignsinc.com or email braillesigns@gmail.com or approved equal. Other manufacturers must submit their signage products to the Architect 10 days prior to the bid date for approval to be considered as an equal.

2.2A PLAQUE SIGNS

A. Provide Braille Signs System 2000 wall plaques with aluminum frame and inlay signs, 9''x 9'' in size. As shown:

ARCHITECTURAL ALUMINUM FRAMES



(* Frames are available in nine anodized finishes: Polished Rose Gold, White, Almond, Brown, and Arch Brown.)

DECORATIVE BARS

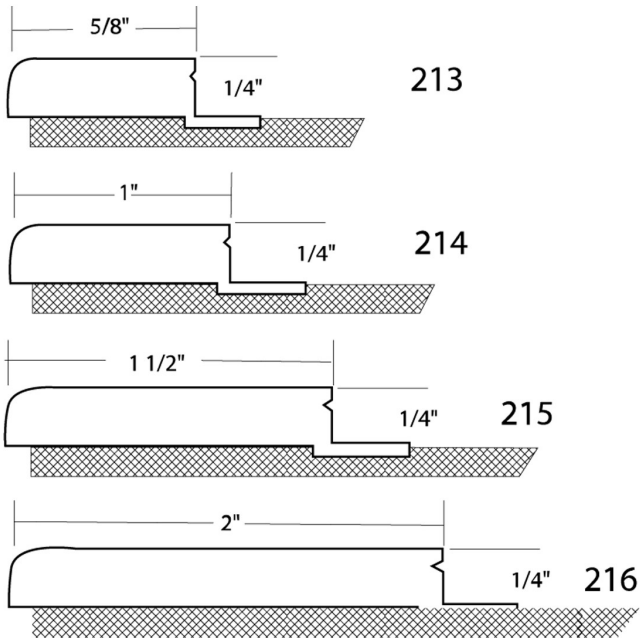

DECORATIVE RAILS

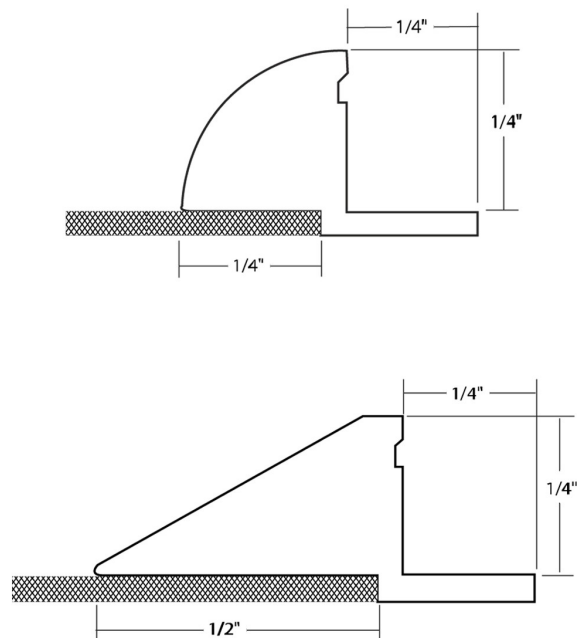

VERTICAL FRAMES

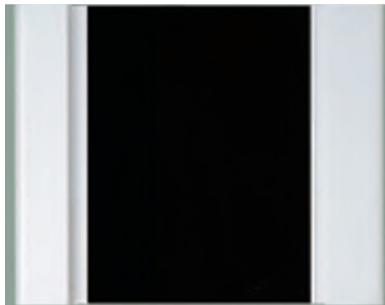

HORIZONTAL FRAMES

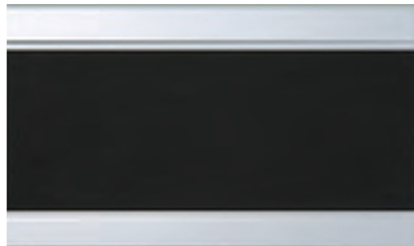

FOUR-SIDED FRAMES



- B. Accessible restroom signage shall be door signs as manufactured by Braille Signs, Inc. and as required by Title 24 and Americans with Disabilities Act (ADA). Provide at rooms indicated in the drawings.
- C. Signs shall comply with all requirements of California Title 24 and ADA.
- D. Signs shall read as indicated on the Drawings.
- E. Colors shall be as selected by the Architect from standard colors of the manufacturer.

2.2B MATERIALS AND FABRICATION

- A. Tactile signs shall be fabricated of 1/8 inch non-glare Mitsubishi Shinkolite acrylic for substrate and 1/6 inch Rowmark material for tactile characters, with “raster” Braille clear acrylic beads.
- B. Signs designed to accommodate inserts for printed room functions or occupant names shall be fabricated of two pieces of acrylic put together with VHB double faced tape.
- C. Ease or round all corners and edges of plaque.
- D. Route all raised character shapes 1/32 inch deep out of top surface of plaque.
- E. Space characters so that top surfaces of characters will have minimum of 1/8 inch between closest point of adjacent characters.
- F. Computer cut raised characters and graphics shall be cut from 1/16 inch integrally colored acrylic. Raise characters and graphics shall be inlaid 1/32 inch into first surface of sign background, secured with adhesive so it cannot be removed without the use of tools. Use VHB adhesive at base of character or use Weld-on acrylic adhesive to chemically bond character to substrate. Fit characters into incised shapes and burnish for full contact. Character must protrude a minimum of 1/32 inch above plaque surface.

- G. All other graphics and color shall be applied to second surface of plaque. Back surface of plaque shall be protected with vinyl.
- H. Interior informational and directional signs shall be fabricated by 1/8 inch non-glare Mitsubishi Shinkolite acrylic. All graphics and color shall be applied to second surface of plaque. Back surface of plaque shall be protected with vinyl.
- I. Ease or round all corners and edges of plaque.
- J. Exterior informational and directional signs shall be fabricated of 0.080 aluminum. Graphics shall be screen printed and exterior quality high performance vinyl, computer cut.
- K. Fasteners:
 - a) Stainless steel tamper-proof screws and plastic anchors.
 - b) Signs mounted on fire-rated doors shall be secured with adhesive.
 - c) Adhesive and sealants shall comply with the limits for VOC content when calculated according to 40 CFR 59, Subpart D (EPA method 24)

2.2 FINISH

A. Signs:

1. Clean out debris from routing procedure around tactile characters.
2. Wipe signs free of smudges after installation

PART 3 – EXECUTION

3.1 EXAMINATION

A. Examine conditions and proceed with Work in accordance with Section 01700.

B. Verify installation area for signs is adequate for size of plaque.

3.2 INSTALLATION

A. Install plumb, level, square and rigidly secured in accordance with Section 01700. Use counter sunk screws for exterior wall signs. Use double faced tape for signs on glass, with backer. Use double faced tape for interior signs on painted walls or doors.